



**Gillison's** Variety  
Fabrication, Inc.  
Manufacturers of quality farm equipment since 1977.

## ROUGH TERRAIN FORKLIFTS

**GVF Rough Terrain Forklifts are fast, powerful machines that operate smoothly. These lifts get the job done quickly and comfortably and now offer Tier IV engines.**

- Models: GVF 5000, 6000 & 8000, available in 2WD and 4WD.
- JCB 444 Tier IV EcoMax engine, 74 HP
- The Tier IV has 20% more torque than the previous Tier III engine.
- Roomier operators platform; 4" wider than before offering better visibility and more elbow room.
- Solid top overhead with a window.
- Fuel system: high pressure common rail
- No exhaust after-treatment
- Extended service intervals
- High efficiency, excellent fuel economy
- See through mast
- 48" carriage with 6 rollers
- 8" side shift in carriage
- Independent power assisted braking which allows operator to use the brakes for turning and decreases pedal effort required for braking which results in better performance and less operator fatigue.
- LED flood lights - front & rear
- LED direction indicator lights
- LED warning flasher lights
- Backup alarm
- Horn
- Tilt and telescoping steering column
- Suspension seat
- Engine pre cleaner
- Grid heater for cold start
- Vertical exhaust
- Rear view mirror
- 4 section hydraulic valve
- 150 cu. in. tool box
- Painted with high quality urethane paint
- Unrivaled reliability
- Options:
  - 2 or 4 wheel drive
  - Warning beacon
  - Bin clamp
  - Bin dumper
  - Rear fender
  - Front fender extensions
  - Transmission brake
  - Load backrest
  - Soft Ride
  - Tire Upgrade



**The Unrivaled GVF Forklifts Offer:**  
**Tier IV engines!**  
**Fast mast cycle speeds!**  
**Exceptional turning radius!**  
**Extremely good visibility!**  
**Fast directional changes!**  
**Easy braking!**

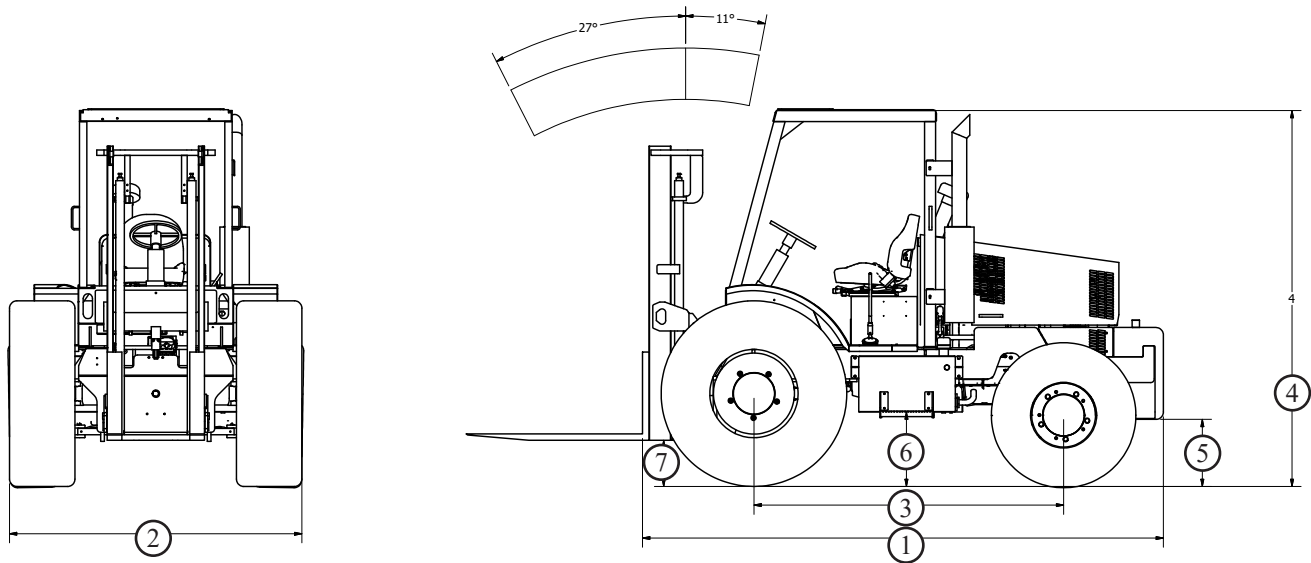

SPECIFICATIONS	Drawing Reference Number	GVF 5000	GVF 6000	GVF 8000
Overall length (without forks)	1	139.5"	139.5"	158"
Overall width	2	80"	80"	87"
Wheel base	3	84"		
Height to top overhead guard	4	102"		
Clearance under counterweight	5	18.5"		
Transmission clearance	6	18.5"		
Clearance under mast	7	13"		
Weight		12,000 lbs.	13,000 lbs.	16,190 lbs.
Lift capacity @ 24" load center		5,000 lbs.	6,000 lbs.	8,000 lbs.
Mast tilt forward		30°	30°	25°
Mast tilt rearward		11°	11°	12°
Mast side shift		8"		
Outside turning radius		12'		
Standard lift height		12'		
Travel speed		18.5 MPH		
Tire Size	GVF 5000 & 6000: Drive: 16.9-24, 10 ply, R4 Steer: 12.5-80R-18, 10 ply, R4	GVF 8000: Drive: 19.5L-24, 10 ply, R4 Steer: 12.5-80R-18, 10 ply, R4		
Steering	Load sense power steering, 2.5 turns lock to lock			

Engine Manufacturer & Model	JCB 444 Tier IV EcoMax
Cylinders	4
Fuel system	High pressure common rail
Engine gross HP	74 @ 2200 RPMs
Peak torque	295 lb/ft @ 1200 RPMs
Start aid cold weather	Grid heater
Transmission	4-speed synchro-shuttle
Fuel tank capacity	25 gallons
Parking brake	External disc
Front axle	Self locking torque proportioning differential internal wet disc brake
Rear axle	4 wd self locking torque proportioning differential 20° oscillation
Hydraulic pump	24 gpm @ 2200 RPMs
Control valve	4 section, 1 aux
System pressure	2600 psi
<b>Electrical</b>	
Voltage	12 volt
Alternator	95 amp
Battery rating	950 cca

2 or 4 wheel drive models available.